

**eulifts**

Thang Máy Châu Âu EuLifts.com

NEXT LEVEL LIVING

  
**ARITCO**<sup>TM</sup>  
Home lifts

The home is the ultimate reflection of you.  
Take your home to the next level.



24



## CONTENT

- 4. Elevate your way of living
- 12. Light up your life
- 14. For all your loved ones
- 18. Five different sizes
- 21. Colour your life
- 23. A piece of new art
- 24. Stand on it
- 29. Key things
- 30. Our story





We believe that ideas can fundamentally improve the world. The dreams of a few have moved the minds of millions. From innovative solutions, to changing perceptions. Defining modern life as we know it. This is what inspires us.

Our journey started 20 years ago with a dream to democratise mobility, driven by a passion for engineering and design. Through the years we have elevated life for thousands of people. Now we are ready for the next level.

We introduce the world's first of its kind, exclusively designed for private homes. Developed and made in Sweden, it has quality and simplicity at its heart.

Customizable and efficient thanks to innovative engineering, it fits in every home, anywhere in the world.

Not only does it raise the overall interior with unique style and lighting – it elevates living. It is innovation for the ever-changing, the forward-thinking. For those who dream of paving the way.

Aritco HomeLift – Next Level Living

  
**ARITCO**<sup>™</sup>  
Home lifts



# The home is the ultimate reflection of you

We know every home is unique, and your home is a special place for you. You have picked every colour, every piece of furniture and every bit of decoration to create a home that is designed for your family, for your life and for your comfort.

A home lift from Aritco is designed to be that extra feature of your home. It is decorative and is a spectacular design feature, which makes your home unique. It provides you with that extra feeling of luxury, and it ignites the full potential of your home.



An Aritco HomeLift opens new possibilities for architectural solutions.

Good design  
has the power to  
enhance life



Aritco HomeLift is designed by  
the Swedish furniture designer  
Alexander Lervik.





There is a big difference between those things in your home that just serve a practical purpose and those that have been specially designed with you in mind, as the homeowner and the user. These are the things that add extra value and make your life easier and more joyful.

Aritco HomeLift is the first lift that is designed with the homeowner and the private residence in focus. The state-of-the-art design is a joy to the eye. It has a DesignWall with a luxury design not like any other product on the market. Some of Scandinavia's most prominent designers and artists have selected art that you can add to the DesignWall. This makes your home lift not merely a problem solver, but a real piece of art in your home.

The home lift is also designed to be space efficient, to make the most out of every square metre of your home. Our smallest model takes up no more space than a wardrobe.

# A smart solution with style

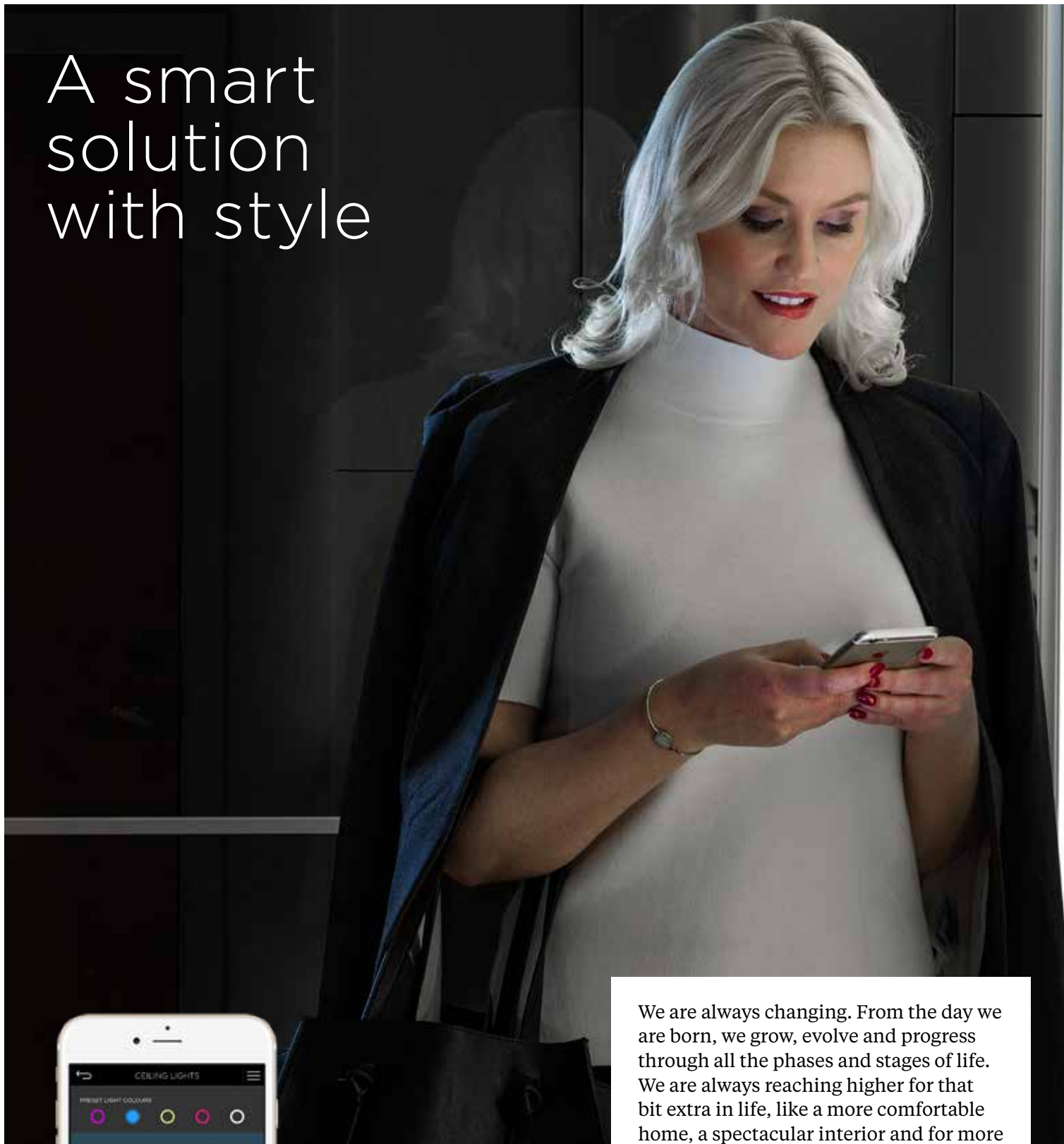

With the Aritco SmartLift app installed on your phone or tablet you can easily set the lighting to fit your mood.

We are always changing. From the day we are born, we grow, evolve and progress through all the phases and stages of life. We are always reaching higher for that bit extra in life, like a more comfortable home, a spectacular interior and for more time with the family.

With clever solutions in your home, you can free up time and energy for those things that really matter – family, friends, spare time and leisure. A home lift simplifies life, whether it is used to carry grocery bags from your garage to the kitchen or enabling your grand parents to join you for dinner. It's also an investment that increases the value of your home. Aritco HomeLift improves the quality of life, every day.



# LIGHT UP YOUR LIFE

Lighting is one of the most important factors for setting a mood and bringing beauty to your interior. It is easy to change the mood in a room, from kids studying at the kitchen table to a cosy dinner with friends, just by changing the lighting. The light sources and light settings should be as carefully chosen as your furniture.

The state-of-the-art lighting design in the Aritco HomeLift is developed by one of Sweden's most innovative lighting experts. Since we know your home changes every day, we have developed a mobile app, called SmartLift, by which you easily can change the lighting in the lift walls and DesignWall to fit your mood and your interior. You can make preprogrammed settings for nighttime lighting and daytime lighting, or easily change the light immediately with the app. Maybe you want a colourful lift for a party? No problem, you simply adjust it with the app.

The app also gives you useful information about the usage, eventual problems or maintenance needs.

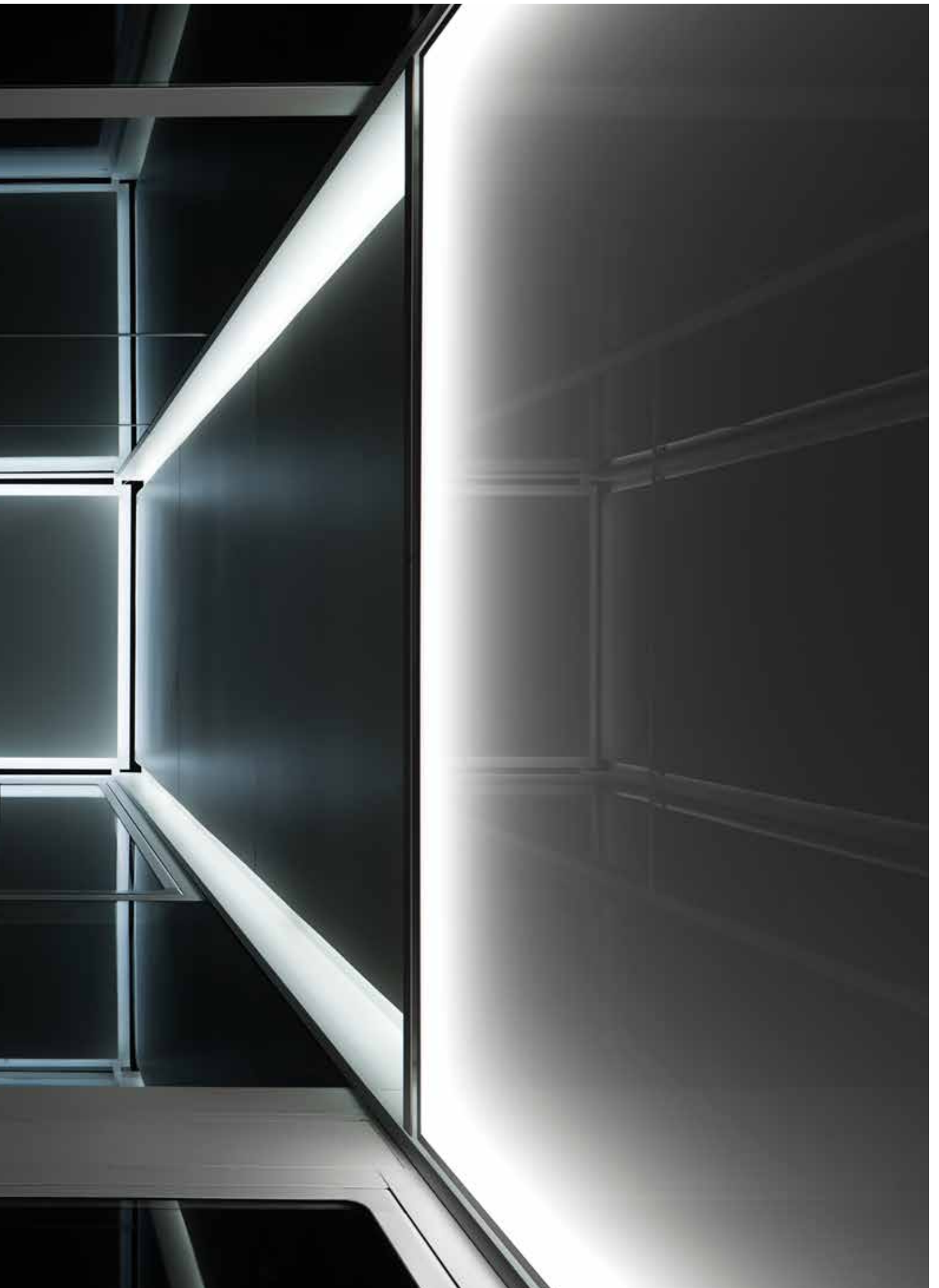



With our Swedish heritage safety and quality is always in focus.



# A HOME FOR ALL YOUR LOVED ONES

Being able to open your home to all the ones you love: your kids, your parents and all your friends, adds extra meaning to life. By having a home that is safe and accessible for everyone, you facilitate many moments of happiness. With a home lift in your home, everyone will feel welcome. Those who don't need to use the lift want to do it anyway, because of the pleasant feeling of entering a room with elegance.

Aritco HomeLift has been designed with both safety and reliability in focus: to meet all kinds of situations that can occur in a home, as well as to prevent accidents. Children may play in the lift and in its vicinity. Therefore, we have smart doors and safety sensors so that small fingers cannot get hurt. You can also activate a lock, so that the children cannot use the lift when adults are not present.

The drive system is a well-tested and reliable screw and nut system that brings the carrier up and down. In addition, we have safety breaks, so that you can always get out of the lift, including during a power failure in the home. All of these safety details are included in our SmartSafety system. For Aritco, it goes without saying that we follow the most stringent requirements and directives for safety.

Quality in every detail makes a home lift work year after year without problems. We care about future generations and therefore use sustainable components that are recyclable.





# Quality in every detail



A high quality product is a lifetime investment. You can love it and use it every day, year after year, and it will just evolve with you throughout life. High quality is also timeless; the product will remain up-to-date while other trends come and go.

The Aritco HomeLift is designed with Swedish quality at its core. Sweden has a heritage of recognised design, safe products and top quality. All of this is also true for the Aritco HomeLift. By designing every detail with care, we have

produced a product with a fantastic finish that is reliable and has a long lifetime. Aritco HomeLift has one of the lowest maintenance costs on the market.

Sweden is well known for its focus on sustainability and the environment. Aritco HomeLift is 95% recyclable and has lower energy consumption than an average washing machine. In general, a home lift from Aritco costs less than 0,2 euro per day to use.

# Aritco HomeLift

TOP FLOOR SOLUTIONS

LIFT COLOUR

DESIGNLIGHT

LIFT WALLS

## CARRIER AND CONTROL PANEL

The carrier consists of the L-shaped platform and a DesignWall that moves up and down when you travel in the lift. The lift is controlled from the control panel in the middle of the DesignWall. By turning and pushing the unique SmartControl on the control panel, you choose the floor and start the journey.

## DOORS

Doors are installed in the lift walls on each floor. The doors are double doors, i.e. two leaves with a central opening. The door leaves are made of glass with painted profiles.



The Aritco HomeLift is available in five different sizes:  
S5, S8, S9, S12 and S15.

Sizes S5, S8 and S9 all have slim design walls, which makes these sizes ideal when the space is limited in the house.

While the larger sizes S12 and S15 are perfect if you for instance like to bring larger things with you in the lift and you have the little extra space in the house.

**Carrier size:** Inner dimensions of the lift  
**Wall size:** Outer dimensions of the lift

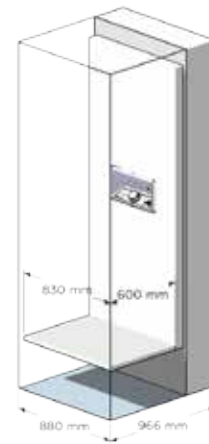

**S5**

**Carrier size:** 600 x 830 mm **Wall size:** 966 x 880 mm  
**Rated load:** 250 kg / 2 persons

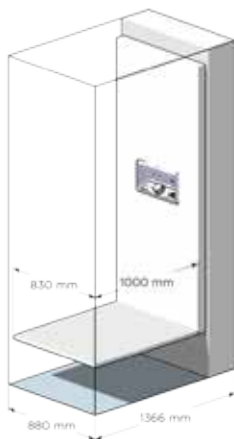

**S8**

**Carrier size:** 1000 x 830 mm **Wall size:** 1 366 x 800 mm  
**Rated load:** 250 kg / 3 persons



**S9**

**Carrier size:** 1100 x 830 mm **Wall size:** 1466 x 880 mm  
**Rated load:** 250 kg / 3 persons

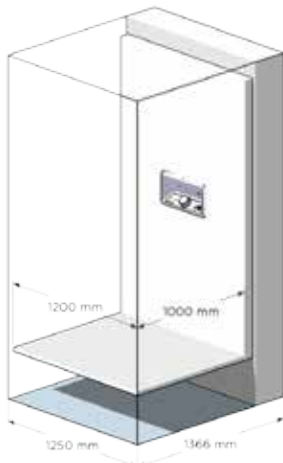

**S12**

**Carrier size:** 1000 x 1200 mm **Wall size:** 1 366 x 1250 mm  
**Rated load:** 300 kg / 4 persons

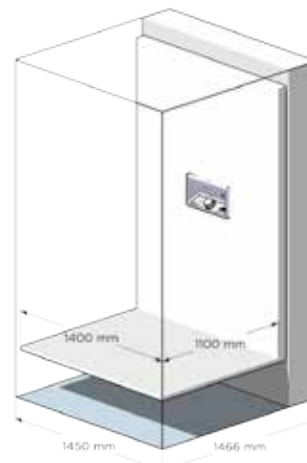

**S15**

**Carrier size:** 1100 x 1400 mm **Wall size:** 1466 x 1450 mm  
**Rated load:** 400 kg / 5 persons

# COLOUR YOUR LIFE

By making some of your own choices for your lift, it will fit nicely into your interior or turn it into a spectacular piece of furniture. We know that every home looks different and understand that you want to design your lift so that it matches all parts of your home.

You can easily see how your lift will look like when using our "build your lift"

at [www.aritcohomelifts.com](http://www.aritcohomelifts.com). Choose where there should be glass walls or covered walls, where the doors will be placed and what colours you want.

The walls of the lift can be either covered or of clear or tinted glass. The walls, frames and doors can be painted in different colours to fit your personal style.



**STANDARD** Whole lift painted in standard colour RAL 9016 (traffic white)

**OPTIONS** Whole lift painted in an optional colour. Walls painted in an optional colour. Doors painted in an optional colour.

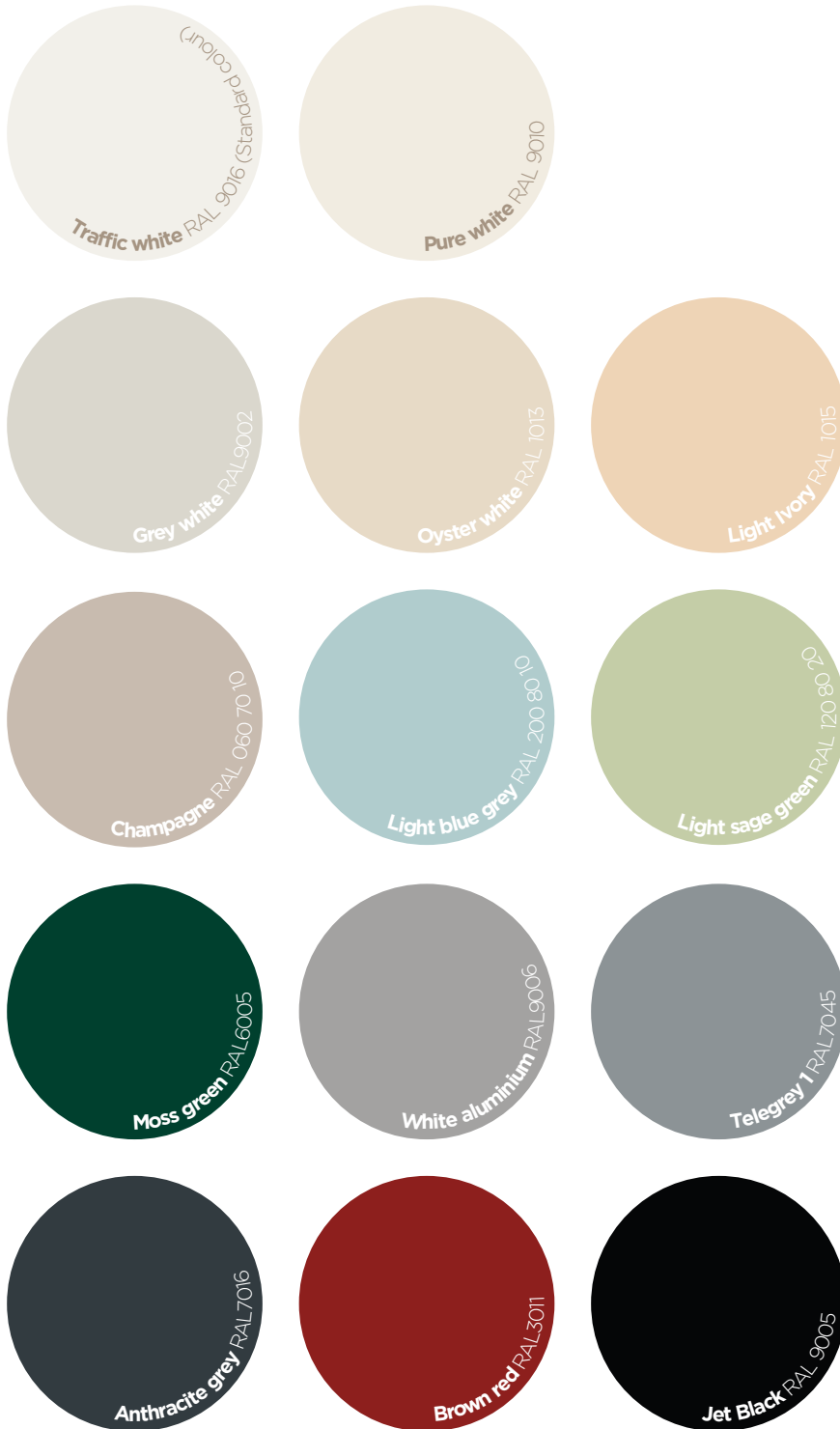

A modern lift with a DesignWall featuring a cityscape and a pair of high-heeled shoes. The lift is shown from a low angle, looking up at the wall. The wall is a light, textured surface with a cityscape visible through the glass. A pair of high-heeled shoes is placed on the floor of the lift. The lift is set against a dark background.

The DesignWall in the lift has a luxurious and unique design. It is, by itself, a piece of art. The standard model is a rear-irradiated white wall of acrylic glass. But by choosing one of our carefully selected designs, you can really make a statement and express your personality. Our designs are picked from some prominent Scandinavian designers and artists. The options evolve over time, so please visit [www.aritcohomelifts.com](http://www.aritcohomelifts.com) for the latest updates.

# A piece of new art

In addition to the standard white DesignWall the following different patterns and pictures are available as option.



**Diagonal**  
by Alexander Lervik

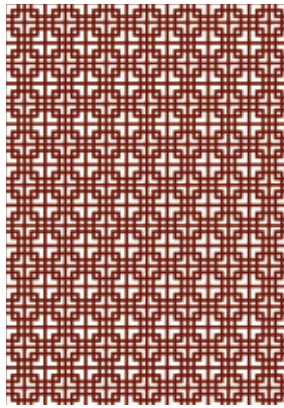

**Orientalic**  
by Alexander Lervik



**Key West**  
by Erik Undéhn



**Skyline**  
by Erik Undéhn



**Sheets**  
by Rikard Lilja



**Structure**  
by Rikard Lilja

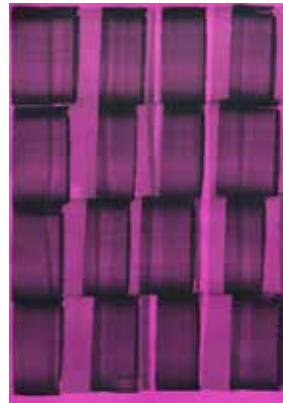

**Pink**  
by Lotta Ingman

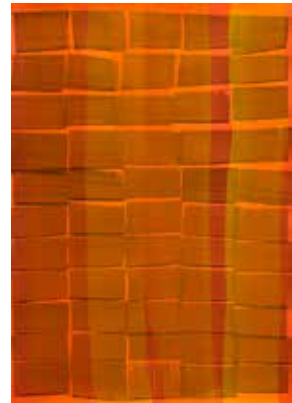

**Orange**  
by Lotta Ingman



The floor of the lift adds an extra touch to the design. You have a number of handpicked floors to choose from that match the colours and the DesignWall of the lift. Your own personal choice is also possible.

# STAND CO



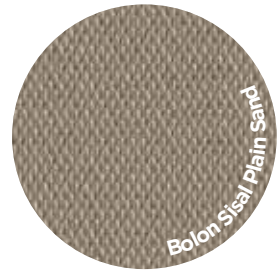

Bolon Sical plain Sand



Bolon Graphic

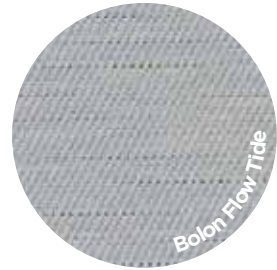

Bolon Flow Tide



Carpet Camel



Carpet Chantli



Carpet Elefant

# Step by step how to acquire your Aritco HomeLift

## 1. 'BUILD YOUR LIFT' AT ARITCOHOMELIFTS.COM

Create a configuration of the Aritco HomeLift that exactly fits your home's needs. Choose the number of floors, where you want covered walls or glass walls, and what colour, floor and DesignWall you desire. With some simple steps you will receive a lift configuration, a price indication and a very good starting point for a discussion with one of the local Aritco Certified Partners.

2. A SALES REPRESENTATIVE from your local Aritco Certified Partner visits your home and answers all of your questions, including the pricing and technical requirements.

3. THE ORDER IS CONFIRMED and the delivery date is set. The delivery time is normally six weeks, so sit back and relax while you wait for your very own home lift to arrive.

4. YOUR SALES REPRESENTATIVE will recommend craftsmen to prepare your home prior to the installation. You will also receive a checklist so that you know exactly what will be done. Everything is carefully planned to make the installation smooth and easy.

5. YOUR ARITCO HOMELIFT is installed. The installation is performed by an Aritco Certified Installer, so that you can be completely confident that the installation is of the highest quality.

6. THE LIFT IS COMPLETED, CE-certified and handed over to you. Use our mobile app, SmartLift, for service, as well as controlling the lights in the lift. The app will automatically notify you when the lift needs repairs.

# Uniquely designed for your home

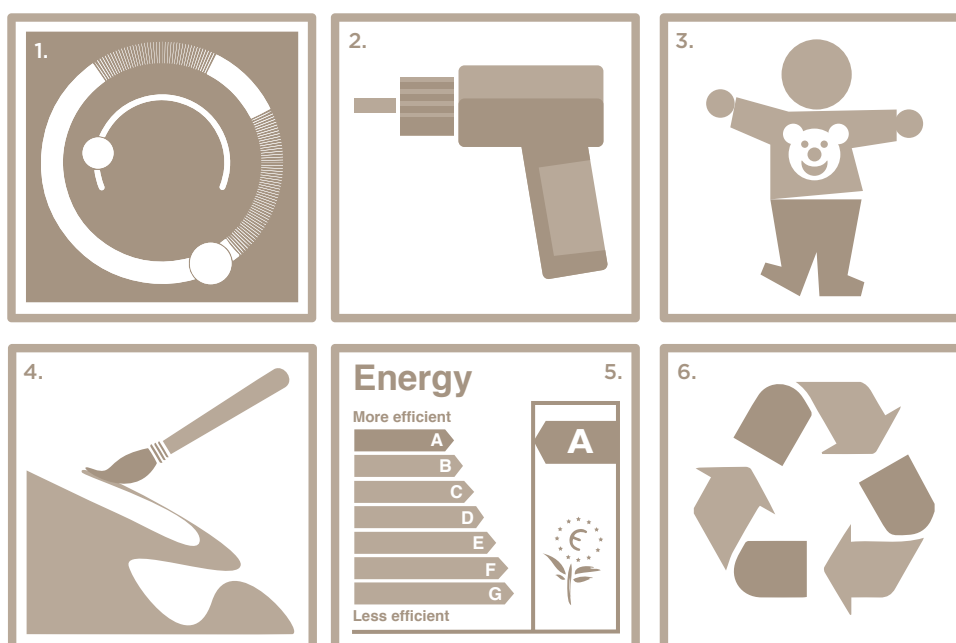

## 1. SMARTLIFT

With the SmartLift app you can control the lighting of your lift from your phone or tablet. You can set up your own lighting schedules, such as having the light turn on and off at predefined times.

## 2. EASY INSTALLATION

The Aritco HomeLift can be installed in just a few days (under normal conditions), so interruption to your daily life is minimal during the installation.

Unlike many other lifts, the Aritco HomeLift can be installed directly on the floor. If you want the lift floor to be flush with the room floor, a pit of just 40 mm is required.

## 3. SMARTSAFETY SYSTEM

The lift is equipped with our SmartSafety system, which includes intelligent doors, safety sensors and dual safety brakes. In the event of

a power failure, the battery-driven emergency lowering system will take you safely to the lowest level and open the doors.

The smart battery guard ensures that the batteries are not discharged if you turn off the lift, or if the power supply is unstable.

Aritco HomeLift is CE-certified, which is a warranty that fulfils high requirements on safety and reliability. Aritco HomeLifts fulfil Europe's most stringent safety regulations.

## 4. CUSTOMIZABLE DESIGN

The lift's DesignWall, SmartLift app and lighting design are features unlike any other product on the market. Flooring and colour options makes it fit any personal preferences. All of which has a touch of Scandinavian design simplicity.

## 5. LOW COST

The Aritco HomeLift has one of the market's lowest maintenance costs. It has a very low energy consumption, less than a typical washing machine, and it is A-rated as to Energy class VDI 4707 standard. With normal usage, it costs less than 0,2 euro per day to run the lift.

## 6. 95% RECYCLABLE

We put great emphasis on the environment to save it for future generations. Therefore, 95% of all the components in the lift are recyclable.

# Drawings

S5

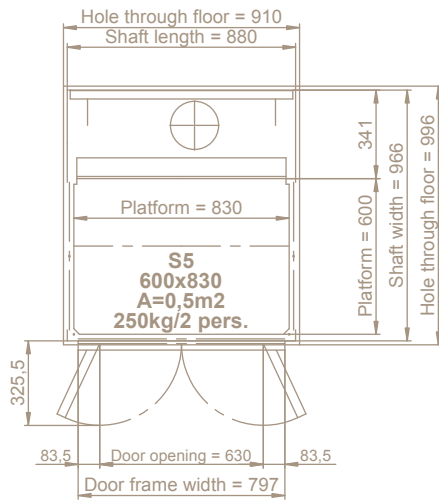

S8

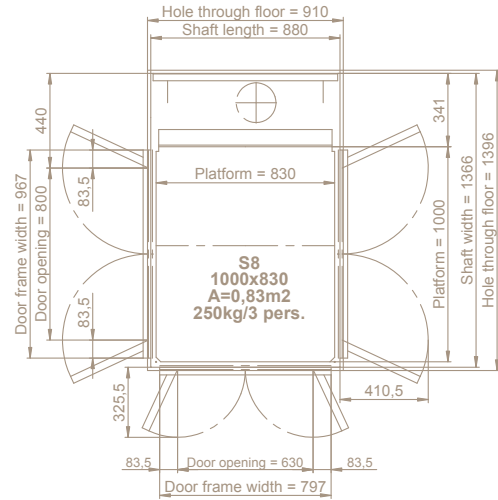

S9

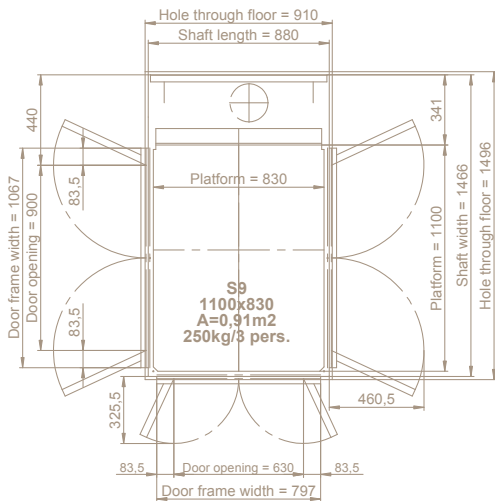

S12

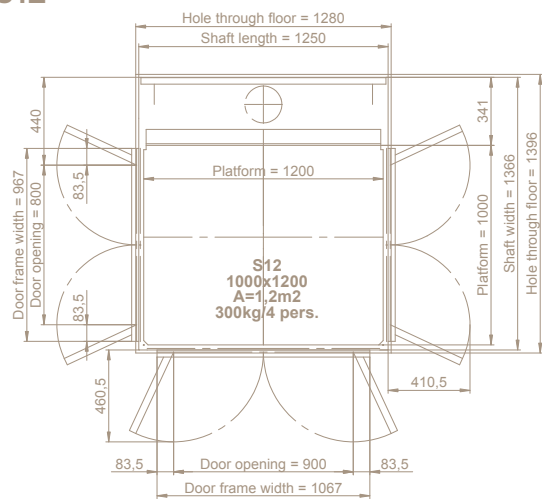

S15

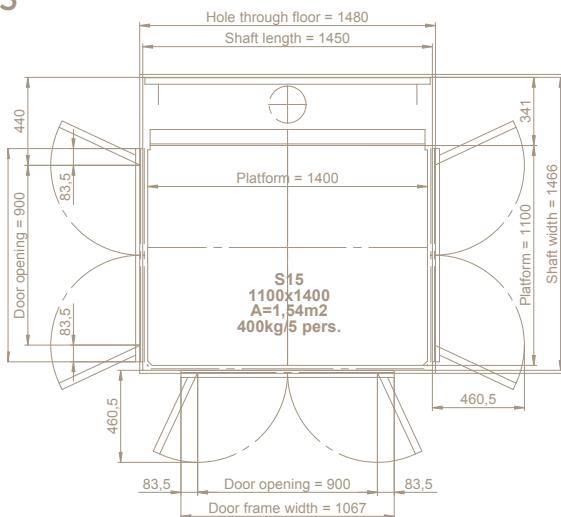

# Product summary

Aritco HomeLift

## TOP HEIGHT

Minimum  
2 200 to  
3 000 mm

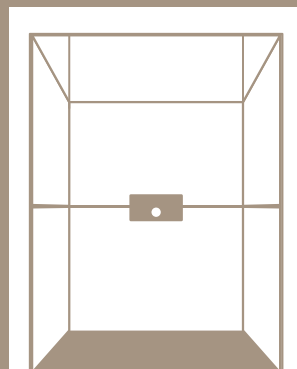

## TYPE OF LIFT

Home lift intended for installation in private homes.

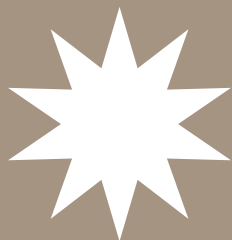

## WARRANTY

Aritco HomeLift comes with a 24 months warranty. The screw and nut assembly has a 10 year warranty.



## DRIVE SYSTEM

Screw/nut system



## RATED SPEED

Max 0,15 m/s Max 0,30 m/s  
(inside/outside Europe)



**INDOOR**  
INSTALLATION ENVIRONMENT

## CONTROL FROM CARRIER CONTROL PANEL

Hold to run - press and hold  
For installations outside  
Europa One touch operation  
(press one time)



**NUMBER OF FLOORS**  
2 to 6 floors



**40**

## INSTALLATION

Recessed installation  
Installed 40 mm below floor  
Installed directly on floor with  
40 mm ramp



## TECHNICAL COMPLIANCE

European  
Machine directive  
2006/42/EC

European  
standard  
EN 81-41

## CARRIER SIZES AND RATED LOAD



Model	Dimensions (mm)	Rated Load (kg)	Capacity (pers)
S5	600x830	250	2
S8	1000x830	250	3
S9	1100x830	250	3
S12	1000x1200	300	4
S15	1100x1400	400	5

## TRAVEL HEIGHT

250–15 000  
millimeter



# Aritco

the world leading home  
lift manufacturer



Our vision is to make home lifts a natural part of homeowners' lives. We want to redefine what a modern home is, making home lifts a must-have for all people striving for a contemporary way of life.

Our journey started 20 years ago, with the simple idea of improving mobility everywhere. Today, you will find Aritco lifts in more than 30,000 buildings and private homes around the world.

Simplicity, quality and innovation are the

common basis of everything Aritco does. We constantly seek new ways to improve, both when it comes to the product, environmental impact and quality, as well as the design and user friendliness. Safety and reliability is a top priority, and, of course, we follow Europe's highest quality and safety standards.

All Aritco lifts are developed and produced in Kungsängen, Sweden, and we are proud to maintain the highest quality in every detail, from design to installation in your home.



Contact us at [www.eulifts.com](http://www.eulifts.com)

